

***Four-Channel
Differential AC Amplifier***

1700

INSTRUCTION MANUAL
FOR
HIGH-GAIN DIFFERENTIAL
AMPLIFIER MODEL 1700

Serial # _____

Date _____

A-M Systems, Inc.
PO Box 850
Carlsborg, WA 98324
U.S.A.

360-683-8300 ♦ 800-426-1306 FAX:

360-683-3525

<http://www.a-msystems.com>

Version 11.0
March 2020

Contents

General Description	1
Operating Instructions.....	4
Theory of Operation.....	6
Specifications	8
Warranty and Service	10

Each Differential AC Amplifier is delivered complete with:

*Four 3' Cables
Rack Mount Hardware*

NOTE

This instrument is not intended for clinical measurements using human subjects. A-M Systems does not assume responsibility for injury or damage due to the misuse of this instrument.

General Description

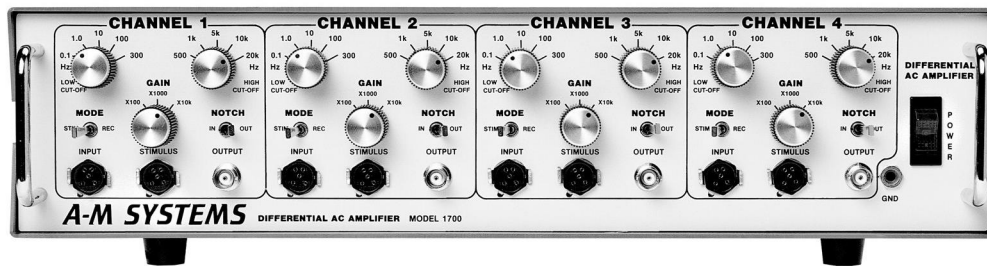

Instrument Features

The *Four-Channel Differential AC Amplifier Model 1700* is designed to amplify cellular neurophysiological signals in applications requiring high gain, high input impedance, low noise, high common-mode rejection, and powerline interference rejection. Typical applications include: extracellular nerve recordings using suction or hook electrodes; electromyographic (EMG) recordings from muscle using wire or needle electrodes; EEG, ERG and EKG recordings. **The instrument is not intended for clinical or operating room measurements using humans.**

The instrument consists of a high input impedance, low-noise differential input stage, followed by high-frequency, low-frequency, and notch filters. The gain settings are x100, x1000 or x10 000. It is also possible to connect a stimulator to each amplifier channel and stimulate through the recording electrodes. The *Model 1700* contains four identical and independent amplifier channels in a single instrument, useful for making extracellular recordings from several sources being monitored simultaneously.

Controls and Connectors

INPUT: This 5-pin connector attaches the electrode cable to the amplifier channel. The pin and electrode cable wire designations can be found in the “Operating Instructions” section in this manual.

STIMULUS: This 5-pin connector allows for external signals to be applied to the electrode.

MODE (STIM-REC): This switch sets the channel to Stimulus Mode or Record Mode. In Stimulus Mode, the **INPUT** connector is connected to the signal from the **STIMULUS** connector and the **OUTPUT** connector is disabled. In Record Mode, the **INPUT** connector is connected to the amplification circuits and the signal is available at the **OUTPUT** connector.

GAIN: This rotary switch sets the amplifier gain to x100, x1000, or x10 000.

LOW CUT-OFF: This rotary switch selects the cut-off frequency of the Low Frequency Filter for the amplifier channel. Signals below the cut-off frequency are reduced by a factor of 100 (40 dB) per decade decrease in the input signal frequency. The Low Frequency Filter may be used to reduce slow DC level variations in the signal being recorded (See Bode plot page 3).

HIGH CUT-OFF: This rotary switch selects the cut-off frequency of the High Frequency Filter for the amplifier channel. Signals above the cut-off frequency are reduced by a factor of 100 (40dB) per decade increase in the input signal frequency.

NOTCH (IN-OUT): This switch allows the Notch Filter to be included (**IN**) in or excluded (**OUT**) from the signal processing circuitry on a per channel basis. When radiation from the power lines is present, it is picked up by recording electrodes creating unwanted interference in the recording signal. This interference can be reduced through proper grounding and shielding techniques. Occasionally it is impossible to reduce this interference sufficiently to record relatively noise-free signals. The Notch Filter can sufficiently reduce the interference. However, this filter causes some distortion in signals below 100 Hz.

OUTPUT: This BNC connector provides the output signal from the amplifier channel.

POWER: This switch turns on power to all four amplifier channels.

GND: This connector is attached to the circuit ground for all four amplifier channels. To obtain low-noise recordings, this terminal may be used to make a ground connection to the recording medium.

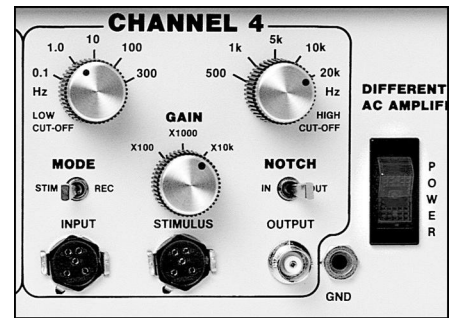

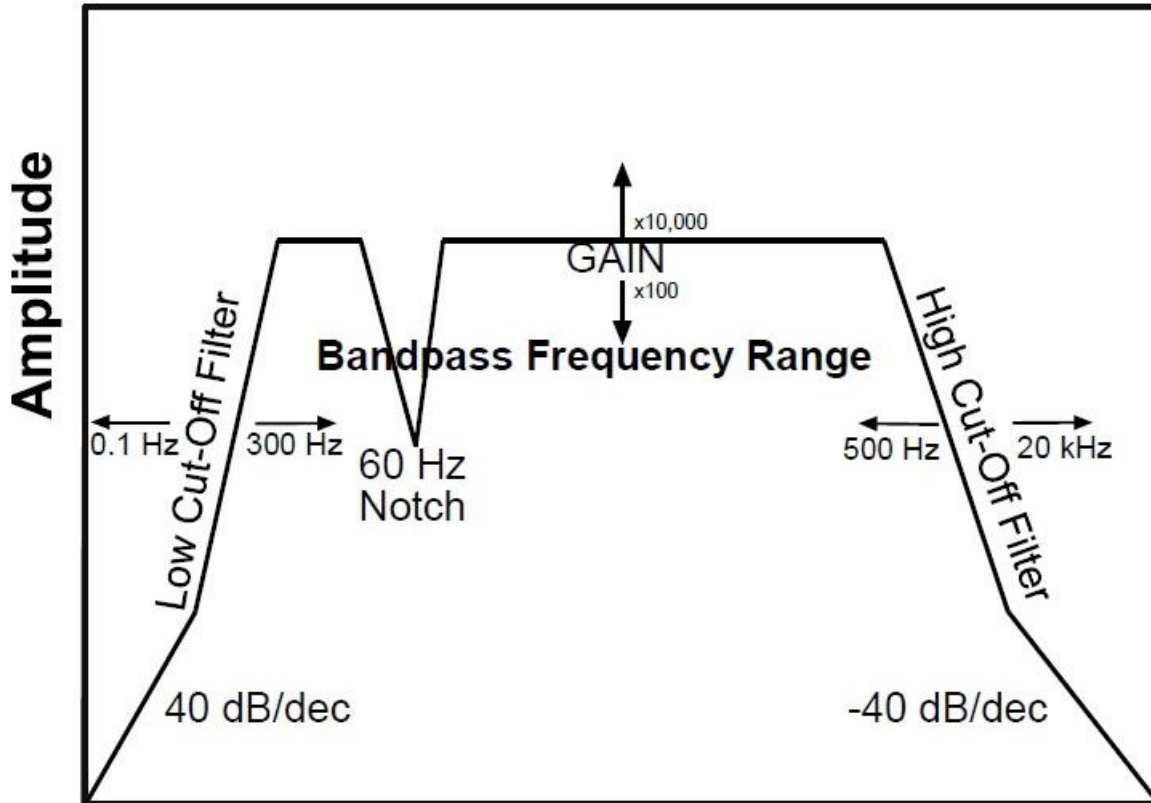

Bode Plot

An input frequency will be reduced in amplitude approximately one-half, when the input frequency equals the instrument panel Cut-Off Filter

Operating Instructions

General Notes

Any amplifier channel not currently in use should have its **MODE** switch in the **STIM** position to protect the amplifier inputs. This grounds the inputs to the differential amplifier circuitry.

Set the **GAIN**, **LOW CUT-OFF** filter, **HIGH CUT-OFF** filter, and **NOTCH** filter according to the frequency content of the signal to be recorded.

While recording from biological preparations take care to keep all instrument cables as far away as possible from the recording situation. This will assist in maintaining proper grounding and shielding to insure a minimum of electrical interference.

Input cables are available to connect the amplifier to extracellular electrodes and/or stimulators. These cables will attach to either the **INPUT** or the **STIMULUS** connector. Additional cables can be ordered (catalog #692000, #701700). One end of each cable is left open to allow for maximum flexibility. The pin assignments for the connectors and the cables are as follows:

Pin	Wire	INPUT	STIMULUS
A	Black	Signal +	+
B	White	Signal -	-
H	Shield	Driven Shield*	Ground
D		not used	not used
E		not used	not used

NOTE: Pin H can be configured to be as a ground, rather than a driven shield. A driven shield is used with the **INPUT** connector to minimize the effect of capacitance on the cable, thus increasing common mode rejection. The shield is driven by a low impedance source with a differential signal voltage from the amplifier. ***This driven shield (the silver braid) should not be connected to ground, as this will cause noise in the input signal.*** Instructions on how to convert pin H to a ground or shield are detailed on the next page. Each channel can be configured independently.

The **STIMULUS** connector shield is connected to the system ground internally. Therefore, any ground-referenced or isolated stimulator can be used with the **STIMULUS** connector.

Configuring Pin H to be Shield or Ground

1) Determine if the channel is already configured as a ground or a driven shield. Using a multimeter, set the meter to check for resistance. Measure between pin H and the front panel ground connector. If the resistance is under 10 ohms, that channel's pin H is set to ground.

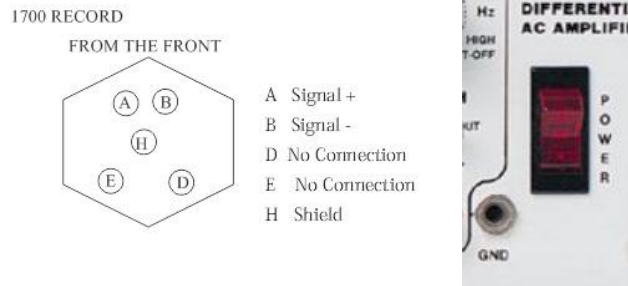

2) To convert the channel so that the braid is a ground, rather than a shield, remove the cover, and look for two large capacitors on rear of the channel board. Near the capacitors is a black jumper (J100). The jumper spans 2 of 3 pins on the connector on the board. If the jumper is near the side marked GND, it is set to ground. If it is over to the other side, it is a shield.

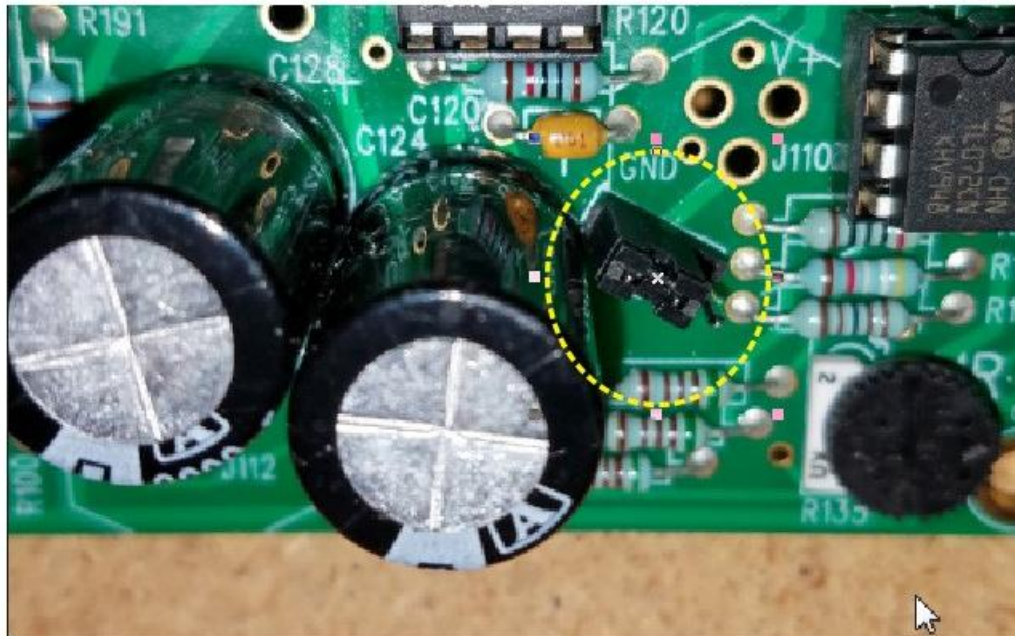

Theory of Operation

Stimulus Mode

In Stimulus Mode, the **INPUT** connector is connected internally to the **STIMULUS** connector to apply the stimulation signal to the electrode. All amplification circuits are grounded in this mode, and the **OUTPUT** connector is disabled.

Record Mode

In Record Mode, the signal from the **INPUT** connector is coupled directly to the inputs of a high impedance, low noise differential amplifier stage consisting of two operational amplifiers with x10 gain. Direct coupling reduces the errors typically associated with capacity input coupling. The operational amplifiers are in non-inverting mode and their gain-setting networks connect through a common resistor to preserve high common-mode rejection.

The common-mode voltage of the input signal at the inverting inputs of the operational amplifiers is measured, and is used to drive the electrode cable shield. This improves the common-mode rejection performance of the input amplifier stage. For this reason, the driven shield *should not* be grounded.

The output signals are then connected to a second differential operational amplifier circuit with a gain of x10. At this point, the differential electrode signal has been amplified by x100 and converted to a single-ended signal with respect to ground. An internal CMR potentiometer is trimmed at the factory to maximize the common-mode rejection.

The signal passes through a double-pole low-pass filter, which attenuates frequencies above the **HIGH CUT-OFF** switch setting. This stage provides no signal amplification.

If selected, the signal next passes through the Notch Filter. The Notch Filter is tuned to the power line frequency and consists of a twin-T network in a feedback loop with an operational amplifier. This stage does not amplify the signal.

The signal then passes through a double-pole high-pass filter, which attenuates frequencies below the **LOW CUT-OFF** switch setting. Also included in this stage is the final amplifier which provides x1, x10 or x100 gain to produce an output signal according to the total gain specified by the **GAIN** switch.

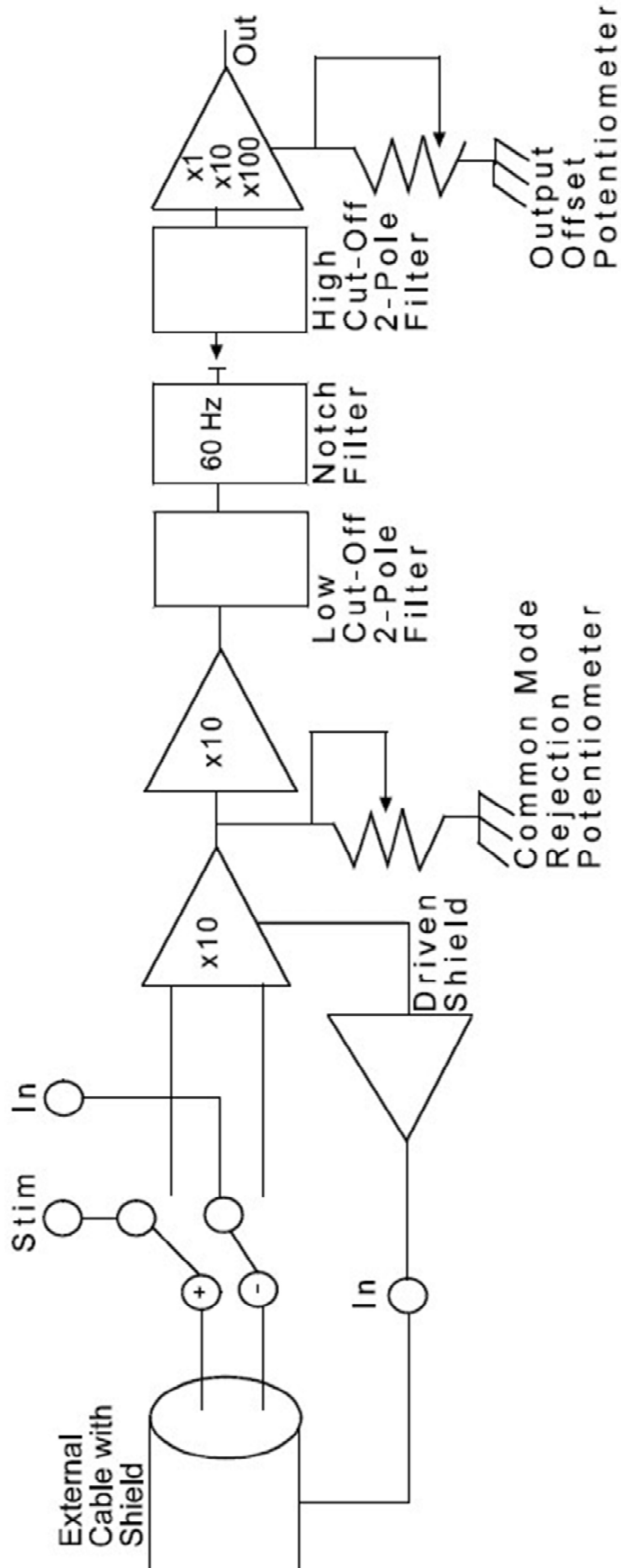

Block Diagram For High-Gain Differential AC Amplifier Model 1700

Specifications

Note: all specifications measured at +25 ° C

Noise

Voltage, $f_o = 10$ Hz	40 nV/Hz ^{1/2} , typical
Voltage, $f_o = 100$ Hz	15 nV/Hz ^{1/2} , typical
Voltage, $f_o = 1$ Hz	8 nV/Hz ^{1/2} , typical
Voltage, $f_o = 10$ kHz	6 nV/Hz ^{1/2} , typical
Voltage, $f_B = 10$ Hz to 10 kHz	0.7 μ V, rms, typical
Voltage, $f_B = 0.1$ Hz to 10 Hz	1.6 μ V, p-p, typical
Current, $f_B = 0.1$ Hz to 10 Hz	15 fA, p-p, typical
Current, $f_B = 0.1$ Hz to 20 kHz	0.8 fA/ Hz ^{1/2} , typical

Offset Voltage

Input offset voltage	± 0.3 mV, typical; ± 2 mV, maximum
Average drift	$\pm 8 \mu$ V/°C, typical; $\pm 15 \mu$ V/°C, maximum
Supply rejection	110 dB, typical

Bias Current

Initial bias current	± 3 pA, typical; ± 15 pA, maximum
----------------------	---

Offset Current

Input offset current	± 3 pA, typical; ± 12 pA, maximum
----------------------	---

Input Impedance

Input impedance	$10^{12}\Omega \parallel > 50$ pF
-----------------	-----------------------------------

Inter-channel Crosstalk

Inter-channel Crosstalk	90 dB @ 1 kHz
-------------------------	---------------

Voltage Range

x 100	.11 V _{AC} or .11 V _{DC} $\pm 5\%$
x 1000	.011 V _{AC} or .11 V _{DC} $\pm 5\%$
x 10000	.0011 V _{AC} or .11 V _{DC} $\pm 5\%$
Common-mode rejection (CMR)	at least 75 dB

Slew Rate

Slew Rate	2 V/ μ s
-----------	--------------

Rated Output

Voltage Output	± 11 V
Current Output	5 mA
Output Resistance	$> 5 \Omega$

Low Cut-Off Filter

Cut-off frequencies 0.1 Hz, 1.0 Hz, 10 Hz, 100 Hz, 300 Hz
Cut-off rate 40 dB/decade

High Cut-Off Filter

Cut-off frequencies 500 Hz, 1 kHz, 5 kHz, 10 kHz, 20 kHz
Cut-off rate 40 dB/decade

Notch Filter

Frequency 60 Hz or 50 Hz, factory preset
Line rejection 30 dB, typical

Power

AC Power source 110 V, 60 Hz or 230 V, 50 Hz, preset
Power usage > 3 W

Operating Parameters

Temperature 20°C to 40°C
Humidity 20% to 75%

Physical Dimensions

Width 17 inches (43.2 cm)
Height 4.75 inches (12.1 cm)
Depth 11.25 inches (28.6 cm)
Weight 19 pounds

Warranty and Service

LIMITED WARRANTY

What does this warranty cover?

A-M Systems, LLC (hereinafter, “A-M Systems”) warrants to the Purchaser that the Instruments manufactured by A-M Systems (hereinafter the “hardware”), and sold after January 1, 2020, is free from defects in workmanship or material under normal use and service for the lifetime of the hardware. Headstages manufactured by A-M Systems and sold after January 1, 2020, will be repaired under warranty only once per year. This warranty commences on the date of delivery of the hardware to the Purchaser. “Lifetime” is defined as the time all components in the instrument can still be purchased from mainstream, common, electronic component distributors such as Digi-Key Electronics, Newark, or Mouser Electronics.

For hardware sold prior to January 1, 2020, the warranty in effect at time of purchase applies, with the maximum warranty period of three (3) years for new purchases, and one (1) year for those that have been repaired by A-M Systems. For headstages manufactured by A-M Systems and sold prior to January 1, 2020, the maximum warranty period is one (1) year.

What are the obligations of A-M Systems under this warranty?

During the warranty period, A-M Systems agrees to repair or replace, at its sole option, without charge to the Purchaser, any defective component part of the hardware. To obtain warranty service, the Purchaser must return the hardware to A-M Systems or an authorized A-M Systems distributor in an adequate shipping container. Any postage, shipping and insurance charges incurred in shipping the hardware to A-M Systems must be prepaid by the Purchaser, and all risk for the hardware shall remain with Purchaser until A-M Systems takes receipt of the hardware. Upon receipt, A-M Systems will promptly repair or replace the defective unit and then return the hardware (or its replacement) to the Purchaser with postage, shipping, and insurance prepaid by the Purchaser. A-M Systems may use reconditioned or like-new parts or units at its sole option, when repairing any hardware. Repaired products shall carry the same amount of outstanding warranty as from original purchase. Any claim under the warranty must include a dated proof of purchase of the hardware covered by this warranty. In any event, A-M Systems liability for defective hardware is limited to repairing or replacing the hardware.

What is not covered by this warranty?

This warranty is contingent upon proper use and maintenance of the hardware by the Purchaser and does not cover batteries. Neglect, misuse whether intentional or otherwise, tampering with or altering the hardware, damage caused

LIMITED WARRANTY, cont

by accident, damage caused by unusual physical, electrical, chemical, or electromechanical stress, damage caused by failure of electrical power, or damage caused during transportation are not covered by this warranty. Further, no guarantee is made regarding software compatibility with future updated operating systems. Products may not be returned to A-M Systems for service, whether under warranty or otherwise, which are contaminated by infectious agents, radioactive compounds or other materials constituting a health hazard to employees of A-M Systems

What are the limits of liability for A-M Systems under this warranty?

A-M Systems shall not be liable for loss of data, lost profits or savings, or any special, incidental, consequential, indirect or other similar damages, whether arising from breach of contract, negligence, or other legal action, even if the company or its agent has been advised of the possibility of such damages, or for any claim brought against you by another party.

THIS EQUIPMENT IS NOT INTENDED FOR CLINICAL MEASUREMENTS USING HUMAN SUBJECTS.

A-M SYSTEMS DOES NOT ASSUME RESPONSIBILITY FOR INJURY OR DAMAGE DUE TO MISUSE OF
THIS EQUIPMENT.

Jurisdictions vary with regard to the enforceability of provisions excluding or limiting liability for incidental or consequential damages. Check the provision of your local jurisdiction to find out whether the above exclusion applies to you.

This warranty allocates risks of product failure between the Purchaser and A-M Systems. A-M Systems hardware pricing reflects this allocation of risk and the limitations of liability contained in this warranty. The agents, employees, distributors, and dealers of A-M Systems are not authorized to make modifications to this warranty, or additional warranties binding on the company. Accordingly, additional statements such as dealer advertising or presentations, whether oral or written, do not constitute warranties by A-M Systems and should not be relied upon. This warranty gives you specific legal rights. You may also have other rights which vary from one jurisdiction to another.

THE WARRANTY AND REMEDY PROVIDED ABOVE IS IN LIEU OF ALL OTHER WARRANTIES AND REMEDIES, WHETHER EXPRESS OR IMPLIED. A-M SYSTEMS DISCLAIMS THE WARRANTIES OF MERCHANTABILITY AND FITNESS FOR A PARTICULAR USE, WITHOUT LIMITATION.

Revision History

Rev	Date	Description
6	6/30/06	Initial Document Control release
7	4/28/10	DCR201200. New warranty info, and company name
8	9/19/16	DCR 202463. Remove calibration instructions.
9	5/15/18	DCR 203014. Update driven shield information
10	1/18/19	DCR 202615. Review content. Add rev control to content
11	3/19/20	DCR 203316. Update warranty.